

IRIDEON

Owner's Manual Composer™ Control System

Reporting Errors and Recommending Improvements

You can improve this manual. If you find any mistakes, or if you know of a way to improve procedures, please let us know. Send your letter to:

Electronic Theatre Controls, Inc.
3030 Laura Lane
Middleton, Wisconsin 53562 USA
Attn: Service Manager

Our FAX number in Middleton is (608) 836-1736.

Revision History

Basic 19 July 1996
Revision A 17 January 1997

COMPOSER™
Control System

Patent and Trademark Notice

Irideon® is a registered trademark owned by Electronic Theatre Controls, Inc., 3030 Laura Lane, Middleton, Wisconsin, USA, and is registered in the United States and other countries. **Composer™**, **AR5™**, **AR6™**, **AR500™**, **Building With Light™**, and the Building Designs are also trademarks owned by Electronic Theatre Controls, Inc.

Irideon products are protected by one or more of the following patents, and other pending patent applications worldwide:

U.S. Patents No. 5,728,994; 5,367,444; 5,186,536; 5,073,847; 4,779,176;
4,602,321; 4,392,187;

U.S. Design Patents No. D 350,408;

Australia Patents No. 683,695; 667,109; 649,264; 646,588; 586,095; 576,400;
546,433;

Australia Designs Reg. No. 128,796; 128,795;

Canada Patents No. 2,070,670; 2,050,375; 1,270,675; 1,259,058; 1,181,795;
Canada Design Patent No. 81,234; 81,233; 76,046;

Europe Design Reg. No. 0586 049; 0 547 732; 0 474 202; 0 192 882; 0 140 994;
0 060 068;

France Designs Reg. No. 370297 - 3703003;

German Patents No (DBP) 96314122.0; 69208615.3; 69121029; 3768727;
3279888; 3274291;

German Design Reg. No. M9402951.2;

Hong Kong Patents No. 965/1990; 285/1987;

Japan Patents No. 2,059,669; 2,055,324; 1,889,481; 1,770,241; 1,723,825;
1,683,007; 1,533,011;

Japan Design Reg. No. 1,002,123; 985,985;

Korea Patent No. 76,310; 42,639

Korea Designs Reg. No. 209,896; 209,895;

Mexico Patent No. 180,148;

Singapore Patents No. 663/90; 134/87;

Spain Patents No. 2.031.748; 2.020.960; 548.328;

Spain Design Reg. No. 137.502; 137.501; 133.573;

UK Design Reg. No. 2056387; 2056386; 2038212

© 1999 Electronic Theatre Controls, Inc. All Rights Reserved

Contents

Chapter 1. Introduction

1.1	Scope	1-2
1.2	Related Documents.....	1-2
1.3	Maintenance	1-2
1.4	Recommended Safety Practices.....	1-2
1.5	Manual Organization.....	1-3
1.6	Technical Assistance.....	1-3

Chapter 2. Description

2.1	Basic Features and Capabilities	2-2
2.2	Configurations	2-10
2.2.1	PC only Control System	2-10
2.2.2	MCP Control System.....	2-12
2.2.3	DMX Interpreter Control System	2-12

Chapter 3. Installation

3.1	Site Preparation	3-2
3.2	Input Power and Control Cabling	3-2
3.3	Installation Procedure	3-3
3.3.1	PC only version	3-3
3.3.2	MCP version	3-3
3.3.3	Remote Control Stations	3-5
3.3.4	DMX version	3-7
3.4	Power Up	3-8

Chapter 4. Test

4.1	MCP / DMX Interpreter System Test.....	4-2
4.2	Remote Station Testing	4-6

Chapter 5. Troubleshooting

Chapter 6. Maintenance

6.1	Power Supply Replacement.....	6-2
6.2	Liquid Crystal Display (LCD) Replacement	6-4
6.3	MCP Circuit Board Replacement	6-6
6.4	DMX Circuit Board Replacement.....	6-8

Limited Warranty

ETC, Inc. warrants to Purchaser that for a period of (12) months from date of installation, but not more than (18) months from date of shipment, the Products shall be free from defects in materials and workmanship under normal use and service. Warranty is limited to (60) days from shipment for sample Products or Products used for rental. ETC, Inc.'s sole responsibility under this warranty shall be to repair or replace, at ETC, Inc.'s option, any nonconsumable part which is defective, malfunctions, or otherwise fails to perform its intended function, when used in a manner consistent with its intended function, provided that customer obtains return authorization in advance from ETC, Inc. and ships prepaid any part of the products to be repaired or replaced under the Limited Warranty to ETC, Inc. or, at ETC, Inc.'s option, to its authorized repair center, within the Limited Warranty period. ETC, Inc. shall not assume any responsibility for any labor expended or materials used to repair any equipment without ETC, Inc.'s prior written authorization. ETC, Inc.'s sole obligations and Purchaser's sole remedy for any Product that is defective, malfunctions, or otherwise fails to perform its intended function when used in a manner consistent with its intended function pursuant to the Limited Warranty is repair and/or replacement of the Product. ETC, Inc. is not responsible for damage to its products through improper installation, maintenance, use, or attempts to operate product above its rated capacity or voltage, intentionally or otherwise, or for unauthorized repairs.

COPYRIGHT

This manual is protected by copyright; Copyright ©, 1999, Electronic Theatre Controls, Incorporated. All rights reserved. No portion of this manual may be reproduced by any process or technique, without the written permission of Irideon, Incorporated.

SOFTWARE LICENSE AGREEMENT

By opening the package containing the **Composer**[™] diskettes and using the **Composer** program, the purchaser agrees that the program remains the exclusive property of ETC and that a personal, non-exclusive license is granted to the purchaser of the equipment to use the program for the operation of the purchased equipment and for no other purpose. A copy of the program may be made for backup purposes. The program may not be reverse engineered, decompiled or disassembled. The creation of derivative works from the program without the written consent of Irideon is prohibited. Upon the resale of the equipment only the rights granted herein shall be transferred to the purchaser. If you have any questions concerning this agreement, please contact ETC at the address indicated below.

If you do not agree to the terms of this agreement, do not open the diskette package. Promptly return it unopened to the place where you obtained it.

Electronic Theatre Controls, Incorporated
3030 Laura Lane
Middleton, Wisconsin 53562
U.S.A.

Irideon[™] and **Composer**[™] are trademarks of ETC, Inc.

Irideon[®] is registered in the United States and other countries.

This page intentionally left blank

Chapter 1 Introduction

This chapter contains the following sections:

- 1.1 Scope
- 1.2 Related Documents
- 1.3 Maintenance
- 1.4 Recommended Safety Practices
- 1.5 Manual Organization
- 1.6 Technical Assistance

1.1 Scope

This manual covers the detailed steps for installation of the ETC IRIDEON® Composer™ control system as well as general information for the owner. Instructions for removing and installing user replaceable items are also located in this manual. For detailed user instructions of the control system refer to the PC Software User's Guide.

1.2 Related Documents

Composer™ PC Software User's Guide: For programming and operation of the **Composer™** control system.

AR5™ Owner's Manual: For installation and operation of the AR5 Luminaire.

AR5™ Service Manual: For technical repair of **AR5** Luminaires.

1.3 Maintenance

The ETC IRIDEON **Composer** control system has been designed to be maintenance free. In the event problems do occur, please contact your local **ETC** distributor or call ETC Technical Support. This manual contains a troubleshooting guide to aid in the identification of failures discovered during initial installation or daily use and for replacement of user replaceable subassemblies.

User replaceable subassemblies are listed below. See Chapter 6 for replacement instructions.

MCP PCB Assembly	7090B5011-1
DMX Interpreter PCB Assembly	7090B5011-2
Liquid Crystal Display (MCP/DMX)	DS129
Power Supply (MCP/DMX Interpreter)	PS143

1.4 Recommended Safety Practices

WARNING: Do not install this equipment with power applied. Ensure incoming power is disconnected prior to installation or maintenance of this equipment.

CAUTION: This equipment is available in 120VAC and 220VAC versions. Do not connect 120VAC version to 220 source voltage or 220VAC version to 120volt source as damage may occur.

1.5 Manual Organization

This manual is divided into six chapters. Chapter 1 contains a brief description of the **Composer** control system, safety precautions, related documentation and what to do about service. Chapter 2 describes the control system in terms of its capabilities, optional components, and possible configurations. Chapter 3 and Chapter 4 discuss installation of the various configurations and how to verify proper operation. Chapter 5 and Chapter 6 are provided to aid in basic troubleshooting and the removal and installation of user replaceable subassemblies.

1.6 Technical Assistance

For technical questions regarding proper installation and troubleshooting of the **IRIDEON Composer** control system, please contact your local **ETC** products distributor or call ETC Technical Support in the United States at 608-831-4116 or 800-688-4116 (FAX: 608-836-1736).

This page intentionally left blank

Chapter 2 Description

This chapter contains the following sections:

- 2.1 Basic Features and Capabilities
- 2.2 Configurations

2.1 Basic Features and Capabilities

The **IRIDEON Composer** architectural lighting control system has been designed to maximize the full potential of IRIDEON multi-parameter luminaires. The **IRIDEON Composer** is a modularized control system consisting of a **Windows 95™** based application for system configuration, programming and playback; and a system controller comprised of either:

- A:** A personal computer (PC) for the simplest configurations, or
- B:** A PC and Master Control Processor for more complex systems, or
- C:** A PC, Master Control Processor and remote control stations for maximum flexibility and convenience.

A DMX Interpreter is available for use with DMX512 consoles.

Software

The **IRIDEON Composer** software is a **Windows 95** based application designed to provide a user friendly means of testing, programming and operating **IRIDEON** interior luminaires. **Composer** software contains step-by-step instructions with easy to understand pull-down help screens to facilitate rapid mastery of its many powerful features.

PC (Personal Computer)

A personal computer is used to program lighting presets and sequences, execute diagnostics, and communicate to the luminaires or Master Control Processor. The PC can connect to the luminaires via their RS-485 communication bus utilizing a RS-232 to RS-485 converter or can be connected to the Master Control Processor using a RS-232 jack located either on the MCP or at a remote receptacle station. The PC can download programmed preset and sequence data to the MCP for later recall and then be removed from the system until updated programming is required.

Minimum recommended requirements for the PC are:

Intel® 486 based PC, 66Mhz

Windows 95 Operating System

Minimum 10MB free hard disk space

Minimum 8MB RAM, 16MB recommended

Serial Port (COM1:, COM2:, COM3: or COM4)

VGA color display

3.5" high-density disk drive

MCP (*Master Control Processor*)

The MCP or Master Control Processor acts as a remote CPU for the control system. The MCP can receive downloaded preset and sequence data from the PC, via a DB9 connector located on the front panel of the MCP or from a remote receptacle station, and store this data after the PC has been removed from the system. The MCP has two dedicated RS485 output ports for the control of up to 31 luminaires each. A third RS485 output port is available for connection of up to 31 remote stations. A fourth output port is reserved for future development use.

A Liquid Crystal Display (LCD) and LED indicator matrix affords constant status of the overall system in addition to displaying the internal clock/calendar.

The MCP houses a 365-day clock/calendar for activation of scheduled events. Events can be defined as presets, sequences, station activation/deactivation, or template assignments. For detailed information on schedules and events (including memory capabilities), see chapter 2 of the User's Guide.

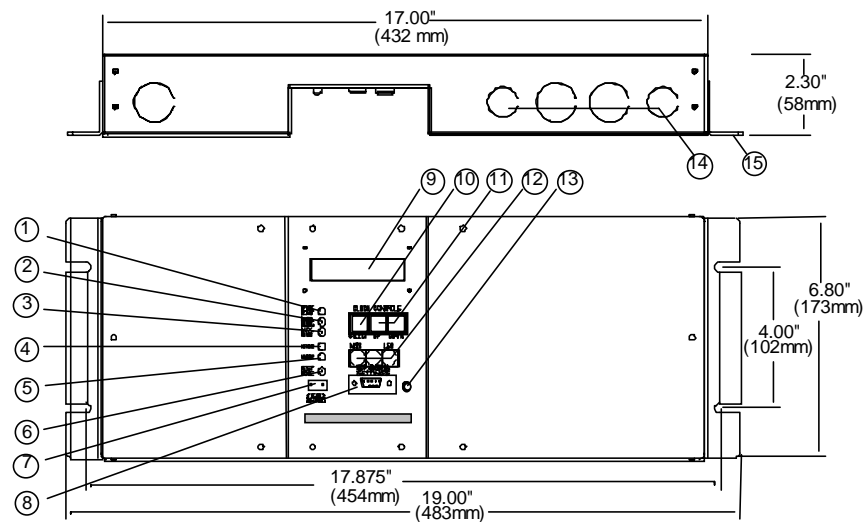

1. **DEVICE COM.** LED indicating data transmission between MCP and luminaires.
2. **CONTROL COM.** LED indicating data transmission between MCP and Remote Control Stations or PC.
3. **AUX. COM.** LED reserved for future application.
4. **5VDC** LED indicating presence of DC logic voltage for control electronics (internal power supply working properly).
5. **24VDC** LED indicating presence of DC voltage to operate remote control stations (internal power supply working properly).
6. **TEST MODE** LED indicating MCP TEST MODE SWITCH is in test position.
7. **TEST MODE SWITCH** Initiates self test of luminaire control.

8. **PC Connect** DB 9 Receptacle for PC connection.
9. Clock / Calendar Display showing Day, Date and Time.
10. **CLOCK CONTROL SELECT** Selects clock/calendar functions to be updated.
11. **CLOCK CONTROL UP/DOWN** Incremental adjustment for Day, Date, and Time.
12. **MCP ADDRESS** Rotary switches for setting address of Master Control Processor (used with multiple MCP configurations).
13. **RESET** Resets processor without removing power.
14. Knock-outs for wiring access.
15. Mounting bracket for rack mount use.

Receptacle Station (RS)

The remote programming receptacle station is a wall mounted RS-232 (DB9 connector) communication link to the MCP allowing temporary location of a PC in the room to be programmed thus providing immediate feedback to programmed effects.

Programming Jack

The programming jack is a wall mounted RJ45 connector allowing direct communication interface from a PC utilizing an RS232 to RS485 converter directly to the luminaires.

Recall Stations (2RS & 8RS)

The recall station acts as a remote control for invoking lighting presets and sequences. These stations are available in 2-button and 8-button versions. Recall stations are provided with LED indicators to reflect status. Recall Stations are for use with the MCP and are not supported by the DMX Interpreter.

Closure Station

The closure station is a remote termination location which provides for the installation of remote sensors and/or switches to activate a programmed event. The actual sensor is defined by the user. Irideon does not offer sensors for use with the **Composer** control system closure capability. Closure stations are for use with the MCP and are not supported by the DMX Interpreter.

Key Switch

The key Switch provides local security to a single recall station or closure station.

DMX Interpreter

The DMX Interpreter converts DMX512 data to Irideon protocol thus allowing Irideon luminaires to be controlled from a DMX console. The DMX Interpreter has two dedicated RS485 ports for the control of up to 31 luminaires each. Standard or Enhanced mode selection determines maximum number of luminaires allowed on each data run. In the case of Standard mode selection, data run #1 supports luminaire addresses "01" thru "31". Data run #2 supports luminaire addresses "32" thru "62". As an example, if 48 luminaires were equally divided between the two data runs. The 24 luminaires on data run #1 would have fixture addresses "01" thru "24" and the 24 luminaires on data run #2 would have fixture addresses "32 thru "55".

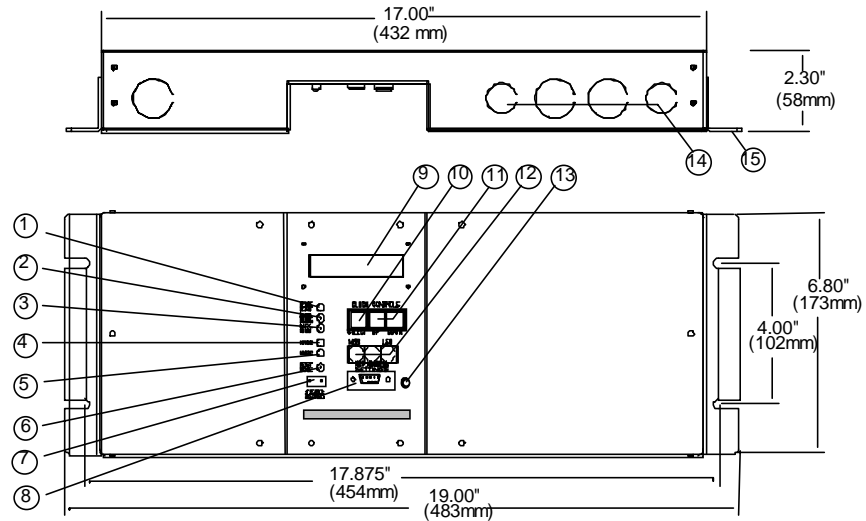

1. **DEVICE COM.** LED indicating data transmission between DMX Interpreter and luminaires on data run #1.
2. **DEVICE COM.** LED indicating data transmission between DMX Interpreter and luminaires on data run #2.
3. **DMX. COM.** LED indicating data transmission from DMX controller to DMX Interpreter.
4. **5VDC** LED indicating presence of DC logic voltage for control electronics (internal power supply working properly).
5. **TEST MODE** LED indicating DMX TEST MODE SWITCH is in test position.
6. **TEST MODE SWITCH** Initiates self test of luminaire control.
7. **PC Connect** DB 9 Receptacle for PC connection. Required for downloading software updates.
8. **LCD DISPLAY** Displays selected bit mode.
9. **MODE STORE** Stores DMX channel mode displayed from up/down arrow scroll.
10. **MENU UP/DOWN ARROWS** Scrolls through channel mode selection menu.
11. **DMX START ADDRESS SETTINGS** Rotary switches for setting DMX Interpreter start address.
12. **RESET** Resets processor without removing power.
13. Knock-outs for wiring access.
14. Mounting bracket for rack mount use.

The first data channel of any luminaire can be calculated by the following:

$$\text{DMX Interpreter starting address} + \left(\text{Luminaire fixture address} - 1 \right) \times \left(\text{\# Channels per luminaire} \right)$$

As an example, if DMX Interpreter start address is set at "001" and the eight bit Standard mode utilizing six data channels is selected (SA 8-6), then the first channel of data for luminaire with fixture address "14" would be: $1+(14-1) \times (6)$ or $1+(13 \times 6) = 70$.

Eight or Sixteen bit mode operation is user selectable. Finer control of pan and tilt can be achieved with Sixteen-bit mode operation. In the Sixteen-bit mode, two channels are utilized for course and fine adjustment of pan/tilt movements thereby increasing step resolution to 512 steps and allowing greater position accuracy.

Standard mode contains no timing provisions. Command execution time is controlled by the DMX control console.

Enhanced mode however, provides the user with three or four separate timing controls, intensity (Douser/Diffuser) timing, focus (Pan/Tilt) timing, Color transition timing and beam transition timing. Timing resolution is one second per step from 0 to 256 seconds.

The DMX Interpreter has a global remote control feature. This feature allows the user to remotely reset all Irideon luminaires and turn lamps on or off. DMX channel #512 is set at the following levels for **3 seconds** and **returned to zero**.

To implement the command:

33% (or 84 out of 256) for RESET

66% (or 168 out of 256) for DOUSE

99% (or 252 out of 256) for START

These settings affect ALL luminaires simultaneously and do not require any additional channels per fitting.

Note: The software feature is implemented in version 2.0 and later version of DMX Interpreter operating systems. The hardware feature is implemented in all Irideon luminaires except for early versions of AR500 and AR5 luminaires.

2.2 Configurations

The ETC **IRIDEON** architectural lighting system consists of **IRIDEON** luminaires and the **Composer** control system. The control system may be supported by only a PC; a PC and Master Control Processor; PC, Master Control Processor and Remote stations; or DMX Interpreter with DMX512 input.

2.2.1 PC only Control System

In the PC only control system, 31 **IRIDEON** luminaires can be supported on a single data run with single zone control utilizing the **IRIDEON Composer** data protocol for luminaire operation.

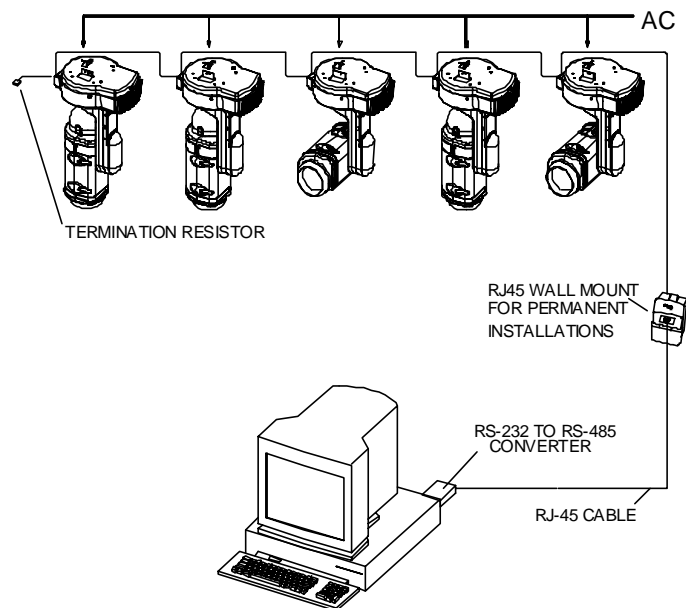

2.2.2 MCP Control System

A control system featuring a Master Control Processor can support 62 **IRIDEON** luminaires on 2 data runs (up to 99 luminaires can be addressed with the use of splitters) utilizing the **IRIDEON** data protocol for luminaire operation. Remote stations provide the added flexibility of recall buttons, entry stations, closure/join stations and receptacles for remote PC connection.

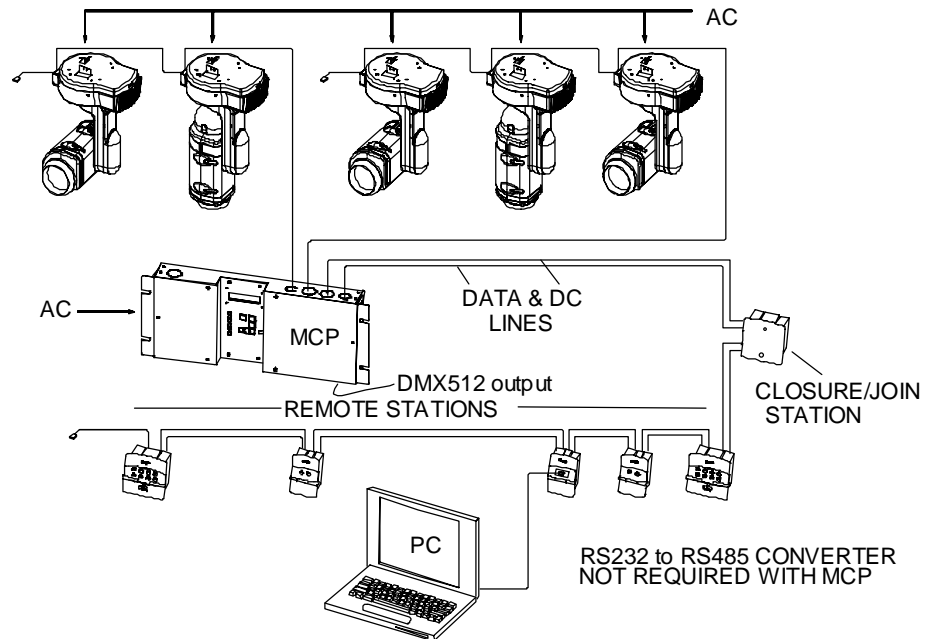

2.2.3 DMX Interpreter Control System

The DMX Interpreter is capable of receiving DMX512 data and converting it to the **IRIDEON** data protocol for luminaire operation. Up to 31 **IRIDEON** luminaires are supported on each of 2 data runs for a total of 62 luminaires.

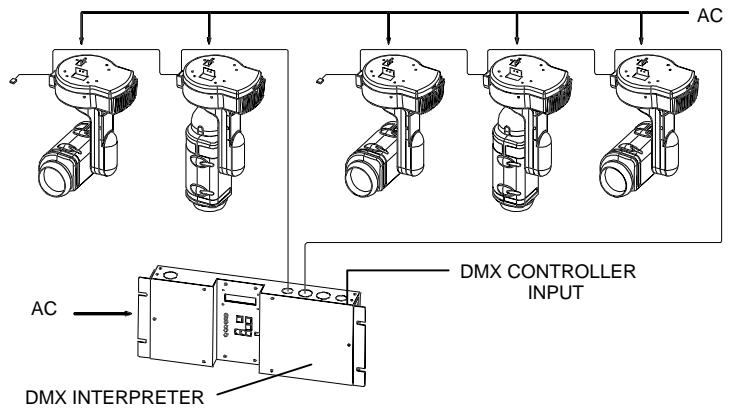

Chapter 3. Installation

This chapter contains the following sections:

- 3.1 Site Preparation
- 3.2 Input Power and Control Cabling
- 3.3 Installation Procedure
- 3.4 Power Up

3.1 Site Preparation

When selecting locations for the MCP and associated remote control stations (if applicable) consideration should be given to the overall length of daisy-chained cable runs. Recommended maximum cable lengths for each luminaire data run and remote control run is 1000 ft.

3.2 Input Power and Control Cabling

Note: The installation contractor is responsible for compliance with local electrical codes.

ETC, Inc. recommends the following cables be used in the **Composer** System:

Signal Type	From Source To:	In Conduit	Without Conduit
Data	Luminaire	Cat 5	Not Recommended
Data	Remote Stations	Cat 5	Not Recommended
DC Power	Remote Stations	Belden 8461	Belden 8790
AC Power	Luminaire	18-10 AWG	Not Recommended
AC Power	MCP	18-10 AWG	Not Recommended

Data and AC power are to be routed through separate conduit. When terminating data and AC power in a common junction box, wiring must be separated by a dividing panel.

Data and DC power from MCP to Remote Stations may be routed through the same conduit. Termination of data and DC power within the junction box does not require isolation of power and data lines.

3.3 Installation Procedure

3.3.1 PC only version

In the PC only control system configuration, a RS232 to RS485 converter must be used to connect to the luminaires. The converter should be located no more than six feet from the PC output. Distance from converter to furthest luminaire is 1000' max. total. A wall mount remote station with RJ45 receptacle is an available option for linking PC to luminaires.

RS485 converter pinout assignments may vary by manufacturer. Check data sheet supplied with chosen converter prior to wiring RJ45 receptacle. When using the RS232 to RS485 converter available from Irideon, the RJ45 receptacle should be wired as follows:

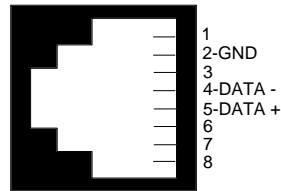

Pin	Wire (Belden 9841)
1	N/A
2	Drain (Ground)
3	N/A
4	Data - (Blue)
5	Data + (White)
6	N/A
7	N/A
8	N/A

3.3.2 MCP version

The Master Control Processor is available in rack mount and wall hung versions.

For rack mount, attach the two mounting brackets to the sides of the MCP and secure into a 4U space on a standard 19" rack.

For wall mount, remove both left and right front panels and secure unit to wall.

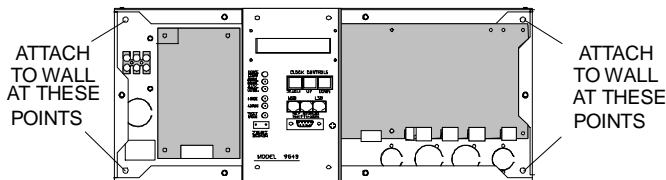

Note: Unit is not designed to recess into wall.

Knockouts are located on top, bottom, and sides of MCP to facilitate hookup.

AC voltage connects to the terminal block located behind the left front panel. In the rack mount version, an IEC connector has been installed on the back panel and wired to the AC terminal block. An IEC power cord is required (not supplied) for the rack mount version of the MCP. DC voltage to Remote Stations and all data connections are to terminal blocks located behind the right front panel.

Two part plug-in terminal strips are utilized to connect wiring from the MCP to the remote stations and the luminaires. Remove the female portion of the terminal strip and attach wiring utilizing the following pin/wire code:

2-Pin DC Power Terminal Strip P2 on MCP feeds Remote Control Stations:

Pin	Wire (Belden 8461)	Wire (Belden 8790)
+	Black	Red
- (Gnd)	White	White

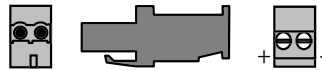

3-Pin Data Terminal Strip P3 on MCP feeds Remote Control Stations:

Pin	Wire (Cat 5)
+	Data + (White)
-	Data - (Blue)
Gnd	Drain

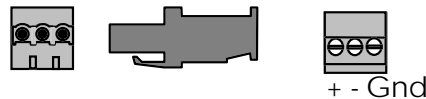

Terminal Strip P5 on MCP feeds luminaire data run # 1:

Pin	Wire (Cat 5)
+	Data + (White)
-	Data - (Blue)
Gnd	Drain

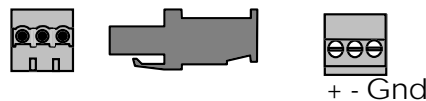

Terminal Strip P7 on MCP feeds luminaire data run # 2:

Pin	Wire (Cat 5)
+	Data + (White)
-	Data - (Blue)
Gnd	Drain

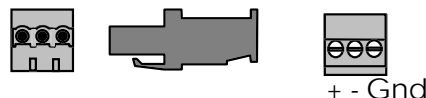

Terminal Strip P9 on MCP for DMX512 output

Pin	Wire (Belden 9841)
+	Data + (White)
-	Data - (Blue)
Gnd	Drain



Connect AC power as shown:

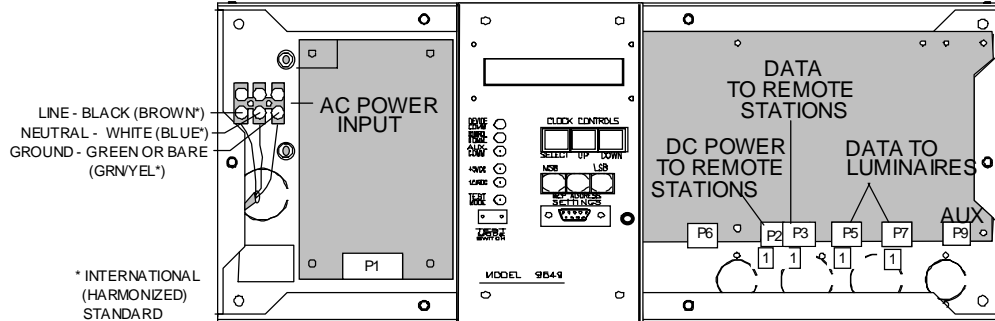

3.3.3 Remote Control Stations

Remote Control Stations which include Recall Stations, Closure/Join Stations, and Receptacle Stations reside on a single data run and are to be wired in a daisy-chain configuration with a 120 ohm termination resistor between the two data lines(+&-) after the last fixture. Maximum recommended cable runs are 1000ft. per channel.

Data and DC power should be run from the MCP and daisy-chained from station to station into approved standard junction boxes. For 8-Button and Closure/Join stations use RACO #681 (4" square x 2-1/8" deep) double box or equivalent. All other stations use RACO #680 single boxes (2-1/2" deep gangable) or equivalent.

Installation of station is accomplished as follows:

- Step 1. Remove the remote station faceplate exposing a 2-position (DC power) and a 3-position (Data) terminal strip and mounting holes for attachment of station to the junction box. For those stations with a hinged cover, screws behind the cover hold the faceplate in place. For those stations without a hinged cover, a screwdriver may be used to gently pry the faceplate loose from the bottom of the station.
- Step 2. The terminal strips are of a two part plug-in style. Remove the outer section to allow wire connection.

Step 3. Connect the data using the following pin/wire code:

Pin	Wire (Belden 9841)
+	Data + (White)
-	Data - (Blue)
Gnd	Drain

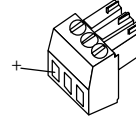

Step 4. Connect the DC power using the following pin/wire code:

Pin	Wire (Belden 8461)	Wire (Belden 8790)
+ (24vdc)	Black	Red
Gnd	White	White

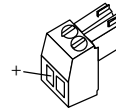

Step 5. Reconnect the two part terminal strips.

Step 6. Using a small screwdriver, set the two rotary switches to the fixture address assigned to the remote station. This information should come from the same source as the luminaire addresses. Remote addresses are not linked in any way to luminaire addresses and may be assigned address numbers also assigned to luminaires without fear of complications.

Step 7. Using the screws provided, secure the remote station in the junction box.

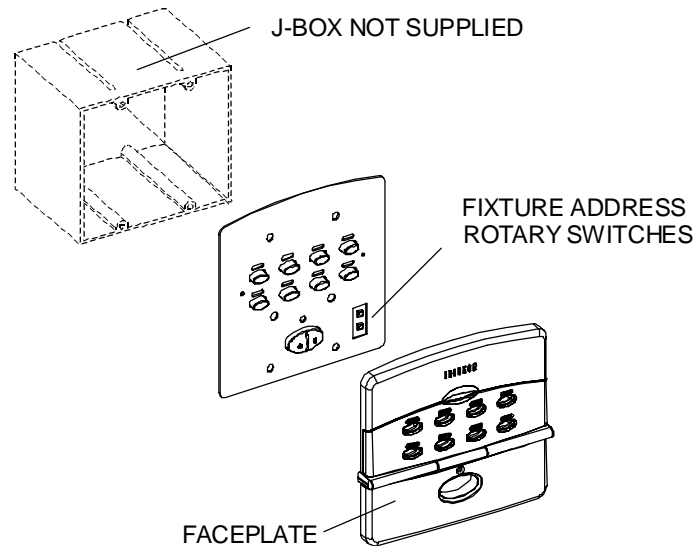

Pin	Wire (Belden 9841)
+	Data + (White)
-	Data - (Blue)
Gnd	Drain

P7 on DMX Interpreter is not used.

Terminal Strip P9 on DMX Interpreter is used for DMX input from console:

Pin	Wire (Belden 9841)
+	Data + (White)
-	Data - (Blue)
Gnd	Drain



An IEC power cord is required (not supplied) for the rack mount version of the DMX Interpreter.

Connect AC power as shown:

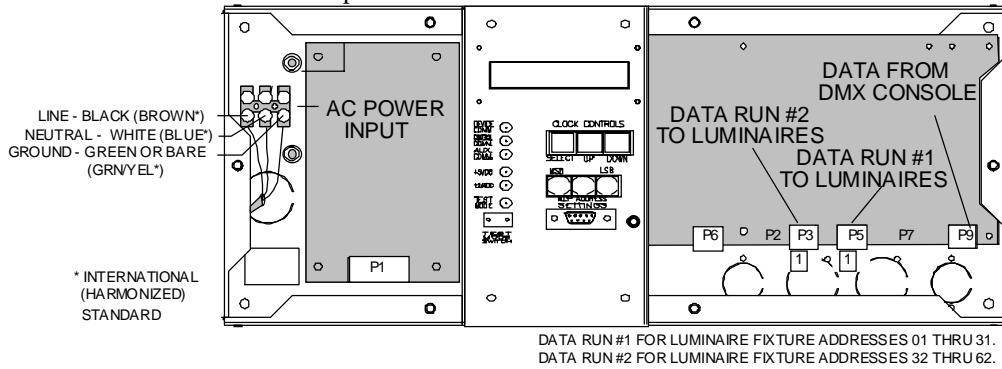

3.4 Power Up

Note: Verify all wiring is properly connected per the above pin/wire tables.
 Verify equipment is properly grounded.
 Verify area around lighting fixtures is clear as calibration of equipment will begin immediately when power is applied to luminaires.

MCP responses. When power is applied, note the following:

- +5 volt and +24 volt LEDs illuminate.
- Device Com LED flashes for approximately two seconds every 20 seconds.
- Control Com LED flashes as it attempts to communicate with luminaires.

- LCD readout displays the resident software version and then shows date and time. Using the select button in conjunction with the up/down buttons, date and time fields may be accessed and updated as needed.

DMX Interpreter responses. When power is applied, note the following:

- +5 volt LED illuminates.
- LCD readout displays “DMX Interpreter”, then software version, then one of four operating modes (“Standard 8 6 CH”, “Standard 16 8 CH”, etc.)

Chapter 4. Test

This chapter contains the following sections:

- 4.1 MCP/DMX Interpreter System test
- 4.2 Remote Station testing

4.1 MCP / DMX Interpreter System Test

Although the MCP and DMX Interpreter are different in functional design, they have been programmed to perform identically during the unit system test. The following test procedure applies to both the MCP and the DMX Interpreter.

The system test is a series of commands resident in the MCP/DMX Interpreter. The commands have been designed to allow the installer/user to observe the various functions of the luminaire for the purpose of verifying proper communication between the controllers and the luminaires. The total test time is approximately one minute. The test will repeat in continuous cycle until test is terminated.

The system test is initiated by setting the test switch located on the face of the MCP to the “test” position.

Before initiating the system test, power up the luminaires allowing them to recalibrate. After successful completion of the calibration sequence, the luminaires will go to their “home” position.

When the test switch is set to the “test” position the luminaires will execute a test routine (refer to the luminaire owner’s manual for details.).

Note: The luminaire has its own internal self test which is initiated with its address switches. To prevent the luminaire’s self test from interfering with the system test, ensure address switches are set to luminaire’s correct address.

During the first part of the test, the installer/user will observe:

- Beam is pointing away from upper enclosure and remains stationary.
- Color changes from blue to amber to magenta.
- All color mechanisms close. This will prevent most light from exiting the luminaire. A small amount of various colors may be observed around the luminaire lens.
- Douser or diffuser panels, if installed, will go to closed position.

Each of the above color states will last approximately two seconds. During this time the installer/user should observe that all filter panels in all color changing mechanisms are opening and closing properly

For the second part of the test, the yoke arm will remain aligned with the finned section of the upper enclosure and the luminaire’s head will tilt 45° from its previous position toward the upper enclosure.

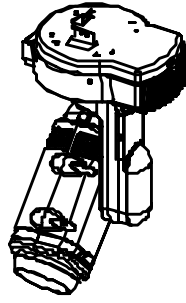

During the second part of the test, the installer/user will observe:

- Head and yoke remain stationary.
- Color changes from blue to amber to magenta.
- All color mechanisms close. This will prevent most light from exiting the luminaire. A small amount of various colors may be observed around the luminaire lens.
- Douser or diffuser panels, if installed, will go to closed position.

As indicated above, each of the above color states will last approximately two seconds.

4.2 Remote Station Testing

Note: For MCP with remote stations only--does not apply to DMX units

When the MCP test switch is placed in the test position, LED status indicator lights will flash indicating data is being received.

The eight button recall station has two rows of buttons and LEDs. The left-most column of LEDs will flash for a period of one second. The column of LEDs just to the right of these will then flash for one second. The third column of LEDs will then flash followed by the fourth column for one second each. At the end of this four seconds, the test sequence will recycle and continue cycling until the test switch is returned to its normal operation position.

The two button recall station responds to this same four second test by flashing the first button during the first second and the second button during the next second. No lights flash during the third and fourth second of the test sequence. At the end of this four second test, the test sequence will recycle and continue cycling until the test switch is returned to its normal operation position.

The receptacle station and closure station both have one LED. This LED will flash at a fast rate for one second, then turn off for one second, then flash at a fast rate for one second. This cycle will continue until the MCP test switch is returned to its normal operation position.

(page intentionally left blank)

Chapter 5. Troubleshooting

Note: If it becomes necessary or desirable to return an item to an authorized service center, a Return Material Authorization (RMA) must be obtained prior to shipment. Items will not be accepted without an RMA number.

Your **Composer**[™] system may consist of:

- A. A personal computer (PC) with **Composer** software and the luminaires.
- B. A PC with software, a MCP with or without remote stations, and the luminaires.
- C. A DMX Interpreter, and the luminaires.

Regardless of the control system in place, it is necessary to isolate the fault to a single piece of equipment. This can be made easier by running the **Composer** system test program. In the PC only control system, the system test program can be found under the **System** menu. For the MCP and DMX Interpreter control systems, the system test switch is located on the front panel of the controller

In general:

If the problem is with all luminaires it is unlikely they have all gone bad at the same time--check the control system.

If the problem is with only one luminaire, check the luminaire. Verify fixture address of the luminaire matches the address entered in the configuration screen of the **Composer** software on the PC (see address settings in the **Composer** User's Guide). Verify start address on DMX Interpreter is correct. Proper operation of the luminaire may be verified by use of the luminaire self test described in the luminaire owner's manual.

The following troubleshooting steps are designed to aid the user in symptom diagnostics.

Luminaire responds properly to system test but not to programmed instructions.

In this instance the control system is directing the luminaire regardless of its address setting and the luminaire is performing properly. Verify fixture address of the luminaire matches the address entered in the configuration screen of the **Composer** software on the PC (see address settings in the **Composer** User's Guide). Verify start address on DMX Interpreter is correct. If address is correct, verify programmed instructions.

All luminaires do not respond properly to controller's system test instructions.

In this instance the controller is not sending the proper instructions.

If a MCP or DMX Interpreter is present, verify DC voltage LEDs are illuminated. If DC voltage LEDs are not illuminated, replace the MCP/DMX Interpreter power supply.

If a MCP or DMX Interpreter is present, verify the Device Comm and Contol Comm LEDs are flashing. If LEDs are not flashing, replace the MCP/DMX Interpreter circuit board.

Individual luminaires do not respond to controller's system test instructions.

In this instance the controller is sending instructions to all luminaires regardless of their fixture address but some are unable to respond. This indicates there is a fault at the individual luminaire. Luminaire troubleshooting tips can be found in the luminaire owner's manual.

Luminaires do not respond to commands from remote stations.

Data from the remote station to the luminaire is routed through the MCP. DC operating voltage for the remote station also comes from the MCP. It is therefore important that the MCP operate properly to support remote station activity.

Verify DC voltage LEDs are illuminated on the MCP. If LEDs are not illuminated, replace the MCP power supply.

Verify fixture address of the remote station matches the address entered in the configuration screen of the **Composer** software on the PC (see address settings in the **Composer** User's Guide). Remote station address switches are located behind the stations faceplate.

Perform the MCP system test and compare the 2-button and 8-button remote's LED activity with that described in the Remote Station Testing section of Chapter 4 in this manual. If errors occur with one station and not with others, replace the station. If errors occur with all stations, replace the MCP circuit board.

Chapter 6. Maintenance

WARNING: Potentially hazardous voltages exist, disconnect power before working on unit.

NOTE: Although the MCP and the DMX Interpreter are different in functional design, they are identical in physical configuration. Each has a power supply, liquid crystal display and main circuit board. The following removal and replacement procedures apply to both the MCP and the DMX Interpreter.

This chapter deals with the removal and installation of user replaceable items and contains the following sections:

- 6.1 Power Supply Replacement
- 6.2 Liquid Crystal Display (LCD) Replacement
- 6.3 MCP/DMX Interpreter Circuit Board Replacement

6.1 Power Supply Replacement

The power supply is mounted to a base plate and the plate is secured to the back wall of the **MCP**. To remove the power supply, first remove the base plate from the **MCP** and then remove the power supply from the base plate.

To remove and replace the power supply:

- Step 1. Remove the three screws holding the left front panel of the MCP in place.
- Step 2. Remove the left front panel of the MCP.

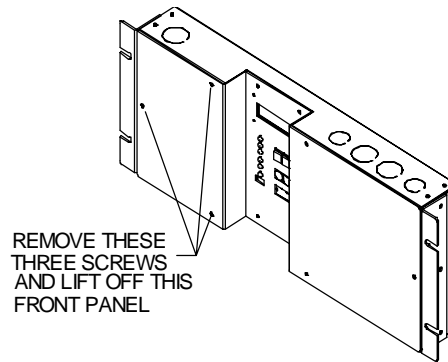

- Step 3. Unplug the cable assembly connected to P1 located at the bottom of the power supply.
- Step 4. Unplug the incoming power connector located in the top right corner of the power supply.
- Step 5. Unplug the Faston crimp connector from the ground lug located in the top right corner of the power supply.

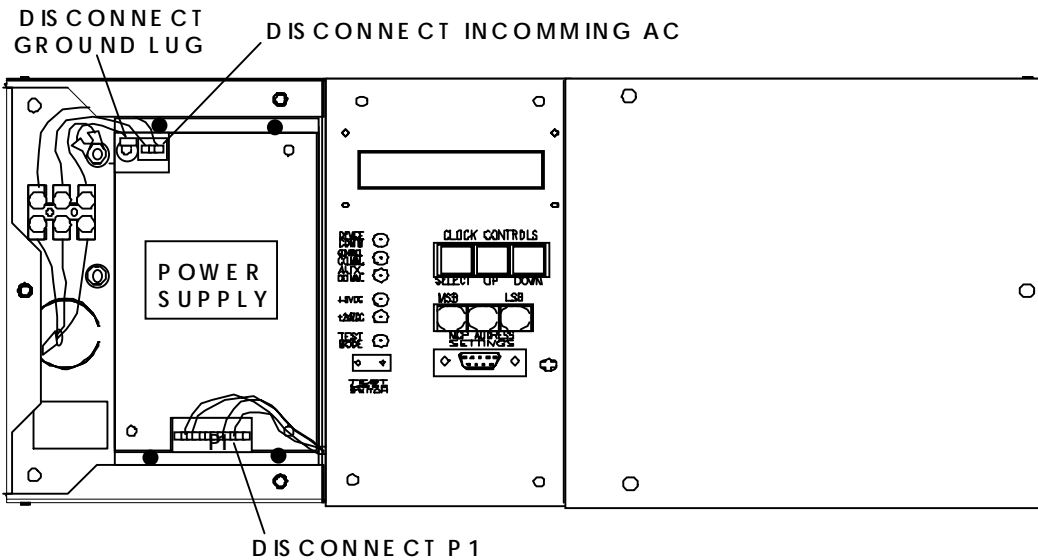

- Step 6. Remove the screws holding the power supply and base plate to the back wall of the MCP and lift out the power supply and its mounting plate.
- Step 7. Remove the mounting base plate from the power supply by removing the four screws on the back of the plate.

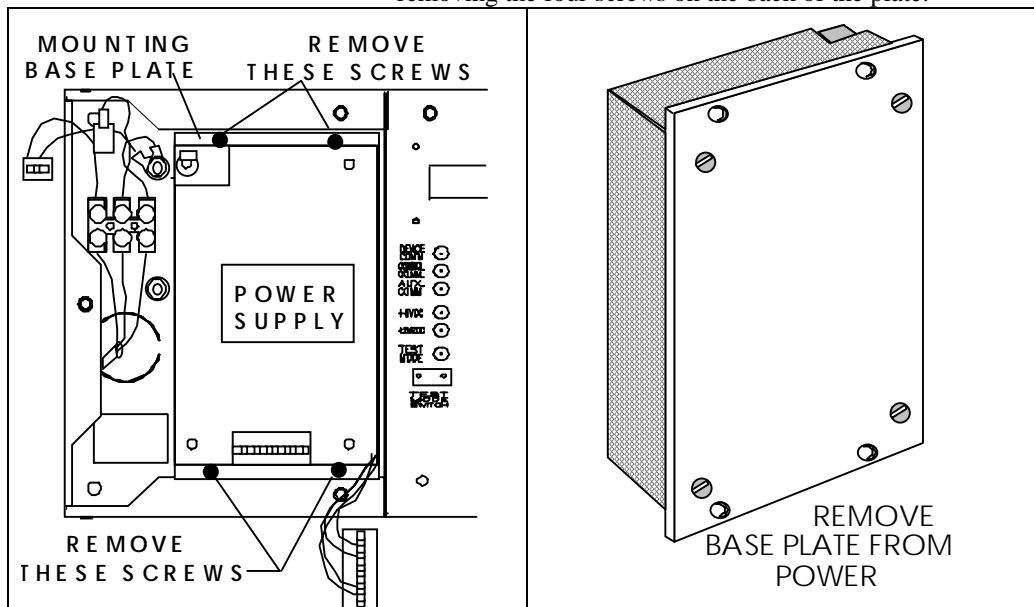

- Step 8. Place the mounting base plate on the back of the new power supply and secure in place with the four screws removed in the above step.
- Step 9. Replace the power supply by performing Steps 1 through 6 in reverse order.

6.2 Liquid Crystal Display (LCD) Replacement

The LCD Display is mounted to the back side of the MCP's center control panel. A ribbon cable connects the display to the main circuit board. It is necessary to lift the center panel and unplug the ribbon cable prior to moving the panel away.

To remove and replace the LCD:

- Step 1. Remove the three screws from the left front panel. Set left panel aside.
- Step 2. Remove the three screws from the right front panel. Set right panel aside.
- Step 3. Remove the four screws from the center front display panel.
- Step 4. Carefully lift the center panel and unplug the ribbon cable from the back of the LCD.

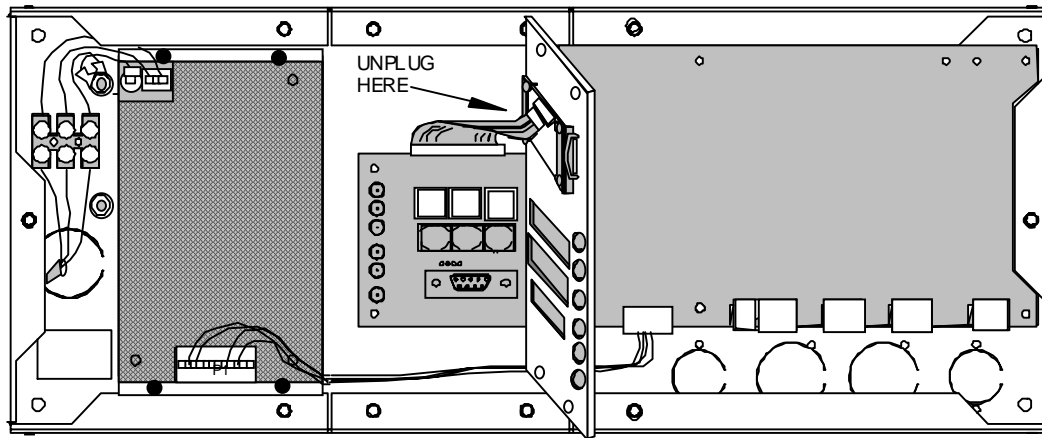

- Step 5. Remove the four screws from the back of the display and lift off the spring holders.
- Step 6. Remove and replace the LCD taking care to ensure the lens remains in place between the LCD and the bezel.

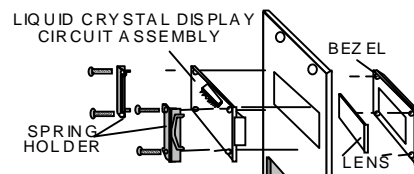

- Step 7. Replace the spring holders.
- Step 8. Thread the four screws through the spring holders, LCD, faceplate, and into the bezel, sandwiching the lens in place and securing the display. Do not overtighten screws.

Note: Do not over tighten as damage to the display may result.

- Step 9. Reconnect the ribbon cable to the display PCB.
- Step 10. Position the center front display panel so that the pushbuttons and DB9 connector extend through the panel. Secure with the four screws removed in Step 3 above.
- Step 11. Replace the left and right front panels and secure in place with the screws removed in Steps 1 and 2 above.

6.3 MCP Circuit Board Replacement

Aside from the power supply and liquid crystal display module, all electronics reside on a single circuit board within the MCP.

To remove and replace the MCP circuit board:

- Step 1. Remove the three screws from the left front panel.
- Step 2. Remove the three screws from the right front panel.
- Step 3. Remove the four screws from the center front display panel.

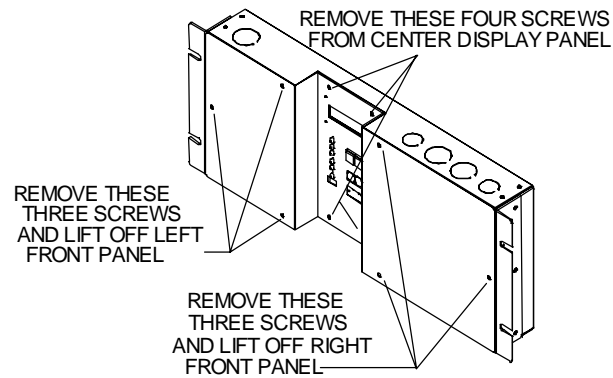

- Step 4. Carefully lift the center panel and unplug the ribbon cable from the back of the LCD.

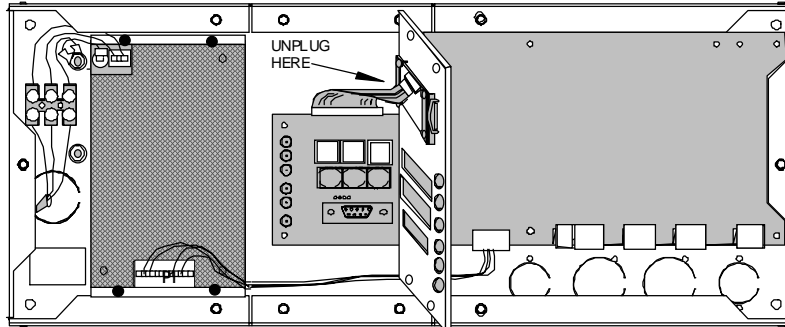

- Step 5. Identify cables to ensure proper reconnection and remove from P2, P3, P5, P6, P7, and P9.

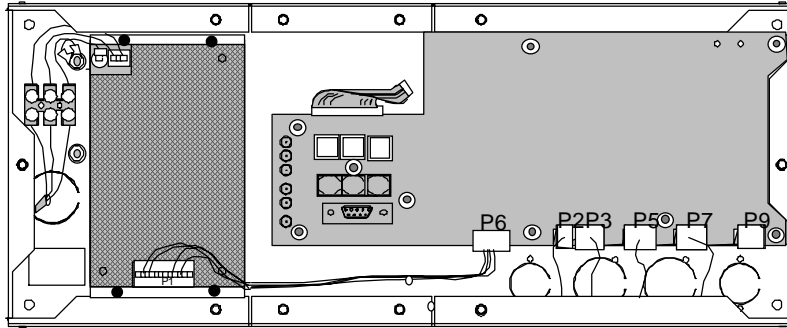

- Step 6. Remove the nine screws securing circuit board in place.

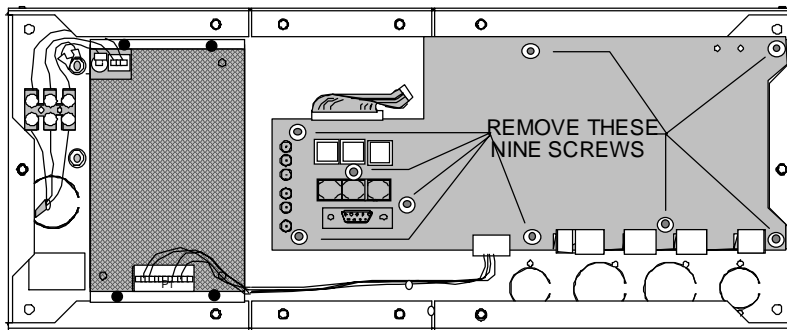

- Step 7. Remove circuit board from chassis.
- Step 8. Remove display module ribbon cable from circuit board and connect to new circuit board.
- Step 9. Install new circuit board and replace nine screws removed in Step 6 above.
- Step 10. Reconnect cables to P2, P3, P5, P6, P7, and P9. Use the following table to assist in proper relocation of identified cables.

Connector	Cable Destination :
P2	Connects +24vdc to remote stations if present
P3	Connects data lines to and from remote stations if present
P5	Connects MCP to luminaire data run #1
P6	Connects power supply to circuit board
P7	Connects MCP to luminaire data run #2
P9	Auxillary connection for future application

- Step 11. Reconnect display module ribbon cable to LCD.
- Step 12. Replace four screws in center front panel.
- Step 13. Replace left and right front panels.

6.4 DMX Circuit Board Replacement

Aside from the power supply and liquid crystal display module, all electronics reside on a single circuit board within the DMX.

To remove and replace the DMX circuit board:

- Step 1. Remove the three screws from the left front panel.
- Step 2. Remove the three screws from the right front panel.
- Step 3. Remove the four screws from the center front display panel.

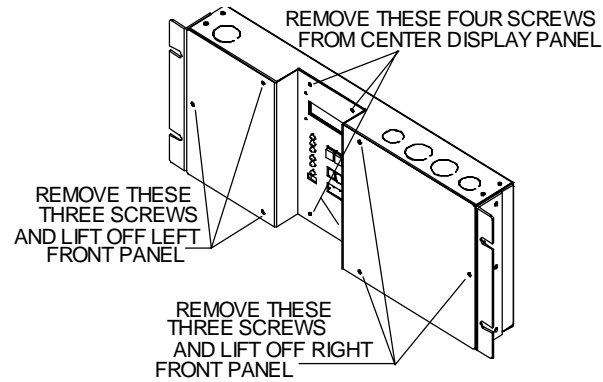

- Step 4. Carefully lift the center panel and unplug the ribbon cable from the back of the LCD.

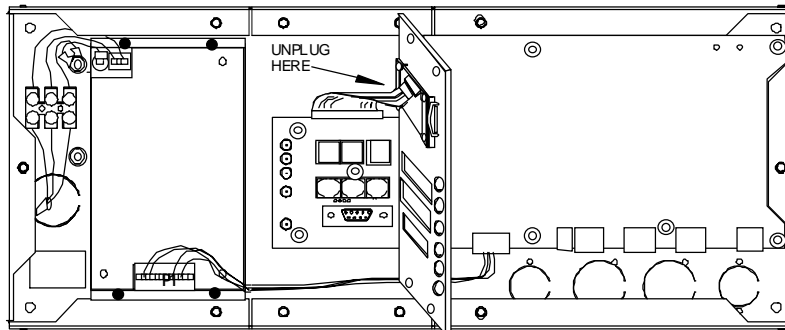

- Step 5. Identify cables to ensure proper reconnection and remove from P3, P5, P6, and P9.

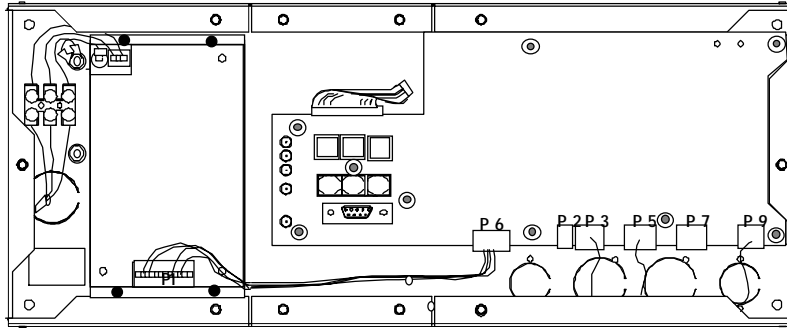

- Step 6. Remove the nine screws securing circuit board in place.

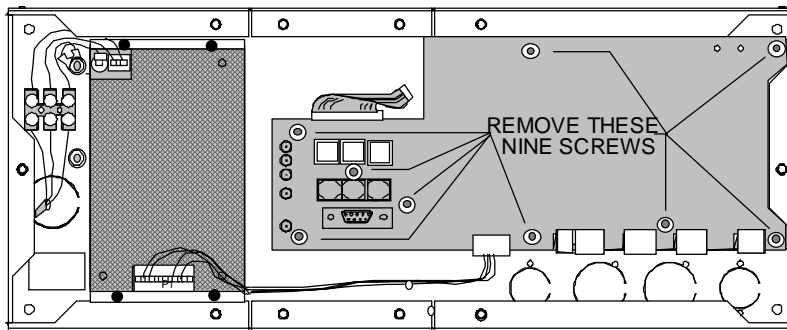

- Step 7. Remove circuit board from chassis.
- Step 8. Remove display module ribbon cable from circuit board and connect to new circuit board.
- Step 9. Install new circuit board and replace nine screws removed in Step 6 above.
- Step 10. Reconnect cables to P3, P5, P6, and P9. Use the following table to assist in proper relocation of identified cables.

Connector	Cable Destination :
P2	Not used.
P3	Connects DMX to luminaire data run #2.
P5	Connects DMX to luminaire data run #1.
P6	Connects power supply to circuit board.
P7	Not used.
P9	Input Data from DMX console.

- Step 11. Reconnect display module ribbon cable to LCD.
- Step 12. Replace four screws in center front panel.
- Step 13. Replace left and right front panels.

This page intentionally left blank